

## KH Beams and TA Beam Towers in Marine Environment

### QUAD BEAMS

<b>PB-50HF-KH</b>	165'/50m Outdoor, 330'/100m Indoor
<b>PB-100HF-KH</b>	330'/100m Outdoor, 660'/200m Indoor
<b>PB-200HF-KH</b>	660'/200m Outdoor, 1320'/400m Indoor

### ANTI-CRAWL BEAM

<b>PB-100AT-KH</b>	330'/100m Outdoor, 660'/200m Indoor
--------------------	-------------------------------------

## FEATURES

### 4 SYNCHRONIZED HIGH POWER BEAMS

'AND-Gated' to prevent 'nuisance-alarms' from birds, animals and blown litter (HF-KH models).

### 'ANTI-CRAWL' FEATURE

For high-security applications the PB100AT-KH model detects low-level or crawling intrusion: selectable AND/OR facility for 2 or 4-beam activation with variable response times for maximum security.

### 'DMPLL' DOUBLE-MODULATED PHASE LOCK LOOP

Our Patented and Proprietary electronic technology, renders the Industry Highest Immunity to accidental or deliberate interference from sunlight, car headlights and other artificial light sources; while at the same time, exhibiting unrivaled RFI and EMI resistance.

### 4 SELECTABLE BEAM FREQUENCIES (CHANNELS)

Allows multiple beams to be used 'in-line' or 'stacked' without 'cross-talk' (interference).

### AUTO-GAIN LOCK / AUTO-GAIN CONTROL

Maintains beam stability in the harshest of weather conditions - eg. fog, rain, snow or frost.

### ENVIRONMENTAL MONITORING

Can be used to warn of the build up of dirt, mist, fog or snow on the protected site.

### EASY BEAM ALIGNMENT

Beam heads adjust horizontally  $\pm 90^\circ$  ( $180^\circ$  total) and vertically  $\pm 10^\circ$ , with signal-strength indicated by audible signal or test-meter: LED indicators for 'Alarm', 'Signal Attenuated', 'Alarm Memory', and LED or audible 'Walk-Test' mode.

### DOUBLE COATED ELECTRONICS

Electronic components are double coated for resistance to corrosion from moisture and condensation.

### 12/24VDC OPERATION

For maximum system flexibility.

## INTELLIGENT PHOTOELECTRIC BEAM SENSORS

# KH

BEAM SERIES

Takex PB-HF-KH Intelligent Quad Beams are designed specifically for use in Takex TA Series Beam Towers. Unique Quad beams are synchronized to maintain range and stability in severe weather, while rejecting 'nuisance-alarms' caused by birds, animals, or blown-litter.

PB100AT-KH Anti-Crawl beams are available for high-security applications to detect low-level or crawling intrusion.

Supplied with PTKH 'Quickfix' mounting brackets for fast, trouble-free assembly, the beam units locate in vertical slide-channels in the TA tower spine, allowing easy and precise height adjustment.

Takex KH Beams and TA Towers are the most economical combination for reliable perimeter intrusion detection in the most demanding of situations - as illustrated in the 'Marine Environment' example above.



# TAKEX

## INTELLIGENT PHOTOELECTRIC BEAM SENSORS



### EXAMPLE APPLICATION

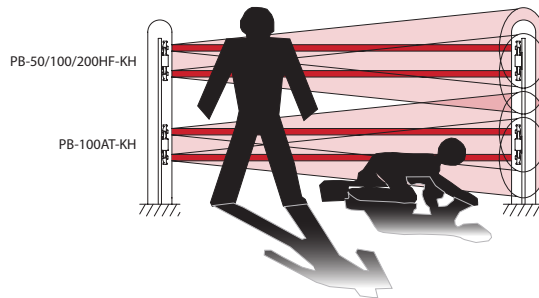

### TERMINAL ARRANGEMENT

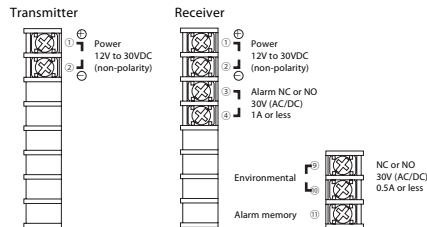

<b>PB-50HF-KH</b>	165'/50m Outdoor - 330'/100m Indoor Quad Beam (4-Channel)
<b>PB-100HF-KH</b>	330'/100m Outdoor - 660'/200m Indoor Quad Beam (4-Channel)
<b>PB-200HF-KH</b>	660'/200m Outdoor - 1320'/400m Indoor Quad Beam (4-Channel)
<b>PB-100AT-KH</b>	330'/100m Outdoor - 660'/200m Indoor Anti-Crawl Beam (4-Channel)

### DIMENSIONS (in mm)

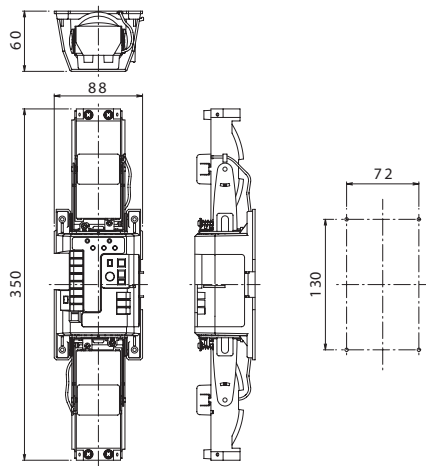

### ASSOCIATED PRODUCTS

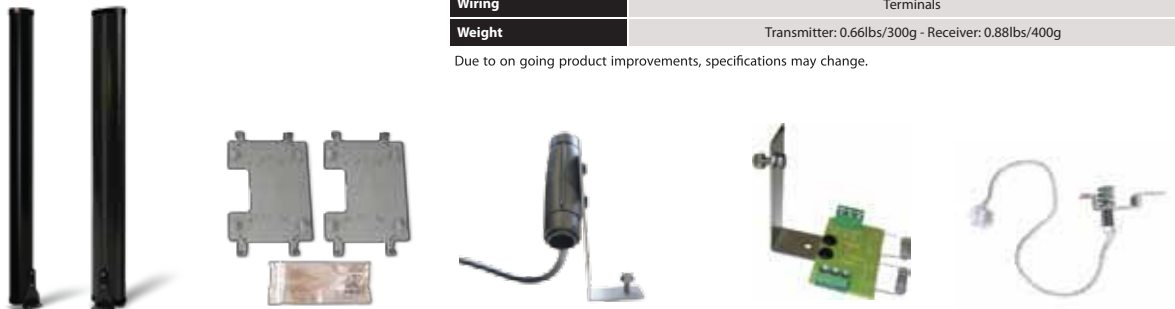

TA SERIES	PTKH	BT-HK12	BT-HK24	TAPS
Takex TA Series Beam Towers are available as attractive but rugged Wall- or Floor-Mount units, as Single- or Double-Sided variants.	'Quickfix' mounting bracket for TAKEX KH Beams. 1 set included with each PBIN-KH beam set.	Heater 12V DC, 255mA to prevent the build-up of condensation or frost on the Tower covers. Use one heater below each side of the Beam pair (2ea/SET TX/RX)	Heater 24V DC, 255mA to prevent the build-up of condensation or frost on the Tower covers. Use one heater below each side of the Beam pair (2ea/SET TX/RX)	Pressure-sensitive Anti-Climb switch for all TA series Towers (activation pressure approx. 44lbs/20Kg).

### SPECIFICATIONS

Product name	Photoelectric beam sensor			
	PB-50HF-KH	PB-100HF-KH	PB-200HF-KH	PB-100AT-KH
Model	PB-50HF-KH	PB-100HF-KH	PB-200HF-KH	PB-100AT-KH
Detection System	Near infrared beam interruption system			
Infrared beam	DMPLL (Double Modulation Phase Lock Loop)			
Protection distance	165'/50m	330'/100m	660'/200m	330'/100m
Max. arrival distance	1650'/500m	3300'/1000m	6600'/2000m	3300'/1000m
Response time	50msec. to 700msec. variable (standard: 50msec.)			Var. 35 to 500msec (AND) 100, 200, 300, 500msec (OR)
Power supply	12V to 30VDC (non-polarity)			
Current consumption	60mA or less at protection (max. 95mA or less)	70mA or less at protection (max. 105mA or less)	85mA or less at protection (max. 120mA or less)	
Alarm output	Dry contact relay output 1c Reset: Interruption time + off-delay (approx. 1.5sec) Contact capacity: 30V (AC/DC) 1A or less			
Environmental output (Fog warning)	Dry contact relay output 1c Contact operation: Output when weather condition worsens Contact capacity: 30V (AC/DC) 1A or less			
Alarm LED	Red LED (receiver) lights when alarm is initiated			
Sensitivity attenuation LED	Red LED (receiver) lights when beam reception is attenuated			
Ambient temperature range	-31°F to +151°F / -35°C to +66°C			
Beam adjustment	Horizontal: ±90° / Vertical: ±10°			
Functions	Modulated beam frequency selection, Tone indicator, Environmental module, Beam power selection, Alarm memory indication, Programmed AGC, Auto-gain lock function, Monitor/jack			
Wiring	Terminals			
Weight	Transmitter: 0.66lbs/300g - Receiver: 0.88lbs/400g			

Due to on going product improvements, specifications may change.

**Note:** These units are intended to be part of an intrusion detection system. TAKEX is not responsible for damages or loss caused by accidents, theft, acts of God (including inductive lightning), abuse, misuse, abnormal use, faulty installation or improper maintenance.

**Takex America**  
 3350 Montgomery Drive  
 Santa Clara, CA 95054  
**Tel:** 408-747-0100  
**Fax:** 408-734-1100  
**E-mail:** info@takex.com  
**Web:** www.takex.com