

ER-S2UV

vented universal 2 space rack shelf

Product Features:

fits components up to 17.375" wide

2 space rack height

tray depth - 14.75"

includes 10-32 and 12-24 rack screws

load capacity - 50 lbs.

static resistant black powder coat finish

Product Specifications:

(for Architects & Engineers)

The vented equipment rack shelf shall be the Video Mount Products (VMP) model ER-S2UV.

The shelf shall be compatible with standard

19" equipment racks without modification.

The shelf shall fit all components up to 17.375" in width. The shelf shall be painted with a durable black static resistant powder coat finish.

The load capacity shall be 50 lbs.

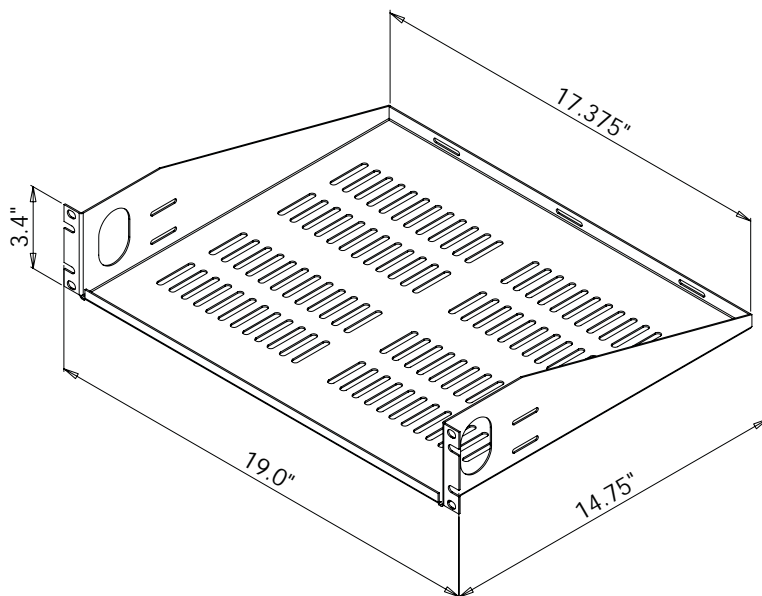

Video Mount Products

325 Log Canoe Circle

Stevensville, MD 21666

Phone: 410.643.6390

Fax: 410.643.6615

www.videomount.com

VMP
VIDEO MOUNT PRODUCTS