

4219 Wired Zone Expander Module – Installation Instructions

GENERAL INFORMATION

The 4219 expander module adds up to eight normally closed or eight end-of-line resistor supervised zones to compatible control/communicators via the control's keypad wiring.

The module may be mounted within the control's cabinet (if room permits), or remotely. If mounted remotely, there are provisions to tamper protect the unit. Communication to the module is supervised so that it cannot be disconnected from the keypad wiring without detection by the control. If the wiring is cut, a tamper alarm or signal will result, to indicate that this device (and possibly other similarly connected devices) has become inoperative.

IMPORTANT: Some carbon monoxide detectors may not be compatible with the Honeywell 4219 hardwire zone expanders. When using carbon monoxide detectors in systems that support the 4219 zone expanders, install the detectors only on the basic hardwire zones of the system control panel, and NOT on the zone expanders.

INSTALLATION



1. Disconnect power before proceeding.
2. Mount the 4219 before making any wire connections.

When the module is mounted remotely, holes on the back of the module's housing permit it to be mounted horizontally or vertically. Wires can exit from the side or the breakout on the back of its housing. For tamper protection, attach the tamper magnet (provided) (Figure 1) to the module inside cover. Place DIP switch position #8 in the OFF position. Affix the connections label that accompanies the module to the inside of the module's cover. When the installation is complete, put the modules cover on. The magnet attached to the cover, positioned near the reed switch, will cause a tamper signal to be sent to the control if the cover is removed.

When the module is to be mounted inside the control's cabinet, mount it horizontally to the raised tabs at the back of the cabinet. Insert self-tapping screws (provided) in two adjacent raised tabs at the back of the cabinet. Leave the heads projecting 1/8". Hang the module on the screw heads via two slotted holes on the back of the module's housing. When the module is installed in the control's cabinet, it need not be tamper protected.

NOTE: For EN50131-3 compliance a tie-wrap must be secured around the case of a remotely mounted 4219.

Apply tie-wrap around the case to the right of the large zone wire opening (4-inch case width). This is in opposition of the tamper switch and magnet.

Affix the connections label that accompanies the module to the inside of the control's cover.

See the control's installation and setup guide for additional information.

CONNECTIONS AND SETTINGS

Zone Connections

Make protection zone connections to the module's 12-position terminal block TB1.

Set DIP switch 7 for the desired zone operation (NC or EOLR):

OFF = End of line resistor operation. Each zone that is used must have a **2K-ohm end-of-line resistor** connected across the end of its loop, as shown in Figure 2.

UL: Set to OFF (EOLR)

ON = Normally closed operation

The method of programming each zone for the type of alarm and reporting code to the central monitoring station varies with the control to which the module is connected. Refer to the Installation and Setup Guide for that control unit.

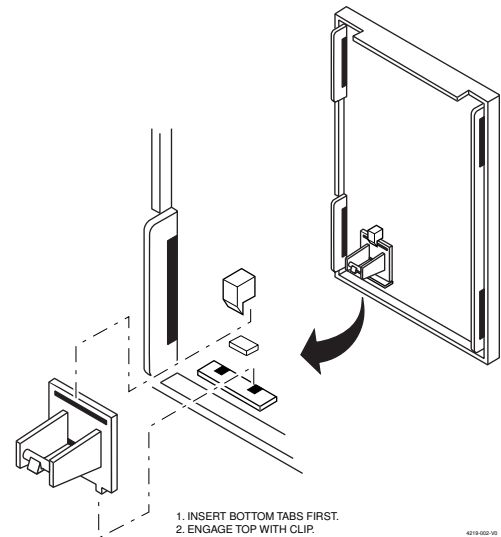

Figure 1. Tamper Magnet Installation

Module Address

Set the module address using DIP switches 2-6.

Select one of 31 addresses, as shown in Figure 3, so the control can identify the module and communicate with it properly. The address to be set is determined by the particular control to be used, and the control's installation instructions must be consulted.

Normal/Fast Response Time for Zone A

Use DIP switch 1 to select normal or fast response time for zone A:

OFF = fast response time of 10ms to an open circuit

ON = normal response time of 300ms. All other module protection zones have a nominal response time of 300ms.

Connection to the Control Panel

Connect the module to the control panel's keypad (ECP) terminals via 4-terminal block TB2 or the 4-pin plug (wire color connections are the same).

SPECIFICATIONS

Physical	6-7/16"W x 4-1/4"H x 1-1/4" D (163mm x 108mm x 32mm)
Electrical	
Input Voltage:	12VDC (from control's remote keypad connection points)
Current:	30mA

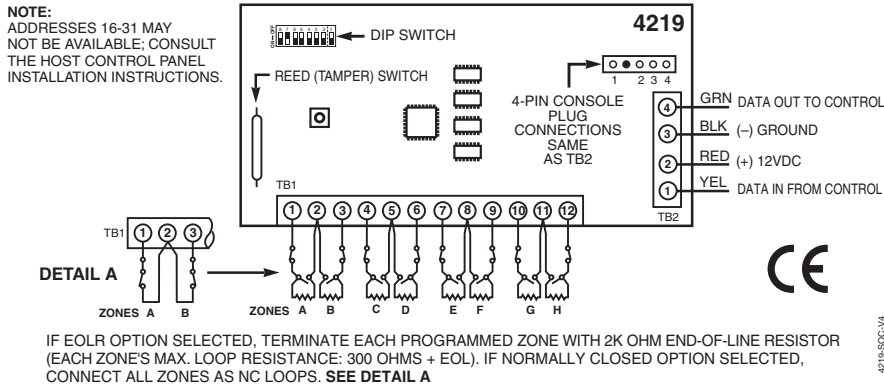

Figure 2. Summary of Connections



EOLR value is 2K ohms.



For UL, use 14-22AWG wire, and no more than one wire may be connected per terminal. Use UL Listed EOL resistors.

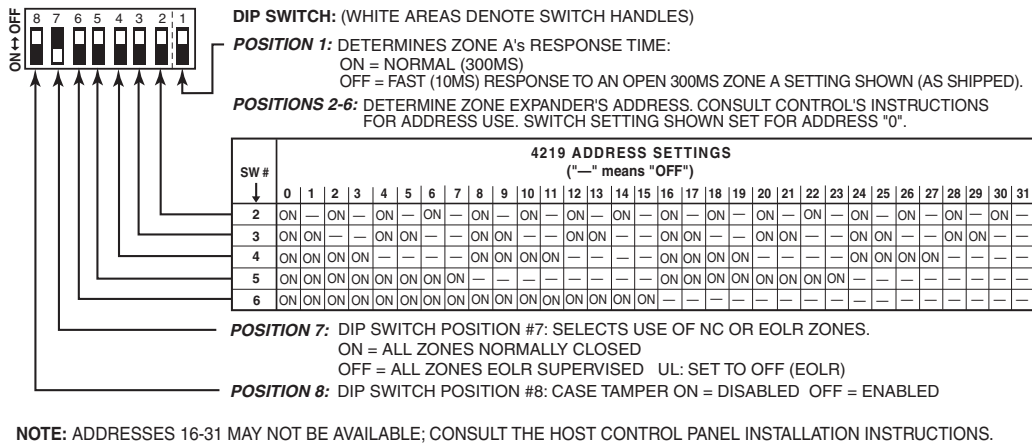

Figure 3. DIP Switch Settings

SEE THE CONTROL PANEL'S INSTALLATION AND SETUP GUIDE FOR COMPLETE INFORMATION REGARDING THE LIMITATIONS OF THE ENTIRE SECURITY SYSTEM.

Federal Communications Commission (FCC) Part 15

The user shall not make any changes or modifications to the equipment unless authorized by the Installation Instructions or User's Manual. Unauthorized changes or modifications could void the user's authority to operate the equipment.

FCC CLASS B STATEMENT:

This equipment has been tested to FCC requirements and has been found acceptable for use. The FCC requires the following statement for your information: This equipment generates and uses radio frequency energy and if not installed and used properly, that is, in strict accordance with the manufacturer's instructions, may cause interference to radio and television reception. It has been type tested and found to comply with the limits for a Class B computing device in accordance with the specifications in Part 15 of FCC Rules, which are designed to provide reasonable protection against such interference in a residential installation. However, there is no guarantee that interference will not occur in a particular installation. If this equipment does cause interference to radio or television reception, which can be determined by turning the equipment off and on, the user is encouraged to try to correct the interference by one or more of the following measures:

- If using an indoor antenna, have a quality outdoor antenna installed.
- Reorient the receiving antenna until interference is reduced or eliminated.
- Move the radio or television receiver away from the receiver/control.
- Move the antenna leads away from any wire runs to the receiver/control.
- Plug the receiver/control into a different outlet so that it and the radio or television receiver are on different branch circuits.
- Consult the dealer or an experienced radio/TV technician for help.

FCC/IC STATEMENT

This Class B digital apparatus complies with Canadian ICES-003.
Cet appareil numérique de la classe B est conforme à la norme NMB-003 du Canada.

This device complies with Part 15 of the FCC rules and RSS 210 of Industry Canada. Operation is subject to the following two conditions: (1) This device may not cause harmful interference, and (2) This device must accept any interference received, including interference that may cause undesired operation.

Cet appareil est conforme à la partie 15 des règles de la FCC & de RSS 210 des Industries Canada. Son fonctionnement est soumis aux conditions suivantes: (1) Cet appareil ne doit pas causer d'interférences nuisibles. (2) Cet appareil doit accepter toute interférence reçue y compris les interférences causant une réception indésirable.



N8924V4 3/14 Rev. B

For the latest warranty information, please go to:
<http://www.security.honeywell.com/hsc/resources/wa>



2 Corporate Center Drive, Suite 100
P.O. Box 9040, Melville, NY 11747
Copyright © 2008 Honeywell International Inc.