



INSTALLATION INSTRUCTIONS
FWC-FSLC-SMK, FWC-FSLC-SMKALG,
FWC-FSLC-HEAT, FWC-FSLC-SMK6B
& FWC-FSLC-SMK4B

These installation instructions are for the FWC-FSLC-SMK, FWC-FSLC-SMKALG, FWC-FSLC-HEAT smoke sensors and FWC-FSLC-SMK6B, FWC-FSLC-SMK4B analog bases.

These instructions apply to all Napco DCP (Digital Communication Protocol) analog sensors and bases. These units must be installed and maintained in accordance with applicable N.F.P.A. standards, local codes and any authority having jurisdiction. Please refer to N.F.P.A. 72 Standard for Automatic Fire Detectors for installation guidelines and testing procedures. Smoke detectors should be tested upon completion of installation and at least semiannually thereafter, in accordance with N.F.P.A. 72, section on "Inspection, Tests and Maintenance".

To install the detector, insert the detector into the base. Turn the detector clockwise until it stops. Tighten tamper screw. Use "3M" Weatherban #606 nonflammable sealing compound to seal field wiring conduit openings in the mounting back box. Compliance with this request may reduce the occurrence of the "STACK EFFECT".

SPECIFICATIONS					
CATEGORY	FWC-FSLC-SMK	FWC-FSLC-SMKALG	FWC-FSLC-HEAT	FWC-FSLC-SMK6B	FWC-FSLC-SMK4B
Absolute Maximum Applied Voltage	39.5 VDC	41.0 VDC	41.0 VDC	41.0 VDC	41.0 VDC
Operating Voltage Range (V _{in}) (S-SC)	22.9 ~ 39.5 VDC	24 ~ 40.7 VDC	24 ~ 40.7 VDC	24 ~ 40.7 VDC	24 ~ 40.7 VDC
Sensitivity Range	SEE CHART BELOW	SEE CHART BELOW	57.2°C ~ 65.5°C (135°F ~ 150°F)	N/A	N/A
Current Consumption (S-SC) Normal Mode	390µA Typical 800µA Maximum	390µA Typical 540µA Maximum	350µA Typical 500µA Maximum	N/A	N/A
Current Consumption (S-SC) When Polled	2mA	2mA	2mA	N/A	N/A
Alarm Current (S-SC)	(See Base)	(See Base)	(See Base)	8mA (Typical)	8mA (Typical)
Remote LED Current	(See Base)	(See Base)	(See Base)	8mA (Typical)	8mA (Typical)
Device Type Code	88 Hex	88 Hex	98 Hex	N/A	N/A
Operating Temperature	-10°C ~ 50°C (14°F ~ 122°F)	-10°C ~ 50°C (14°F ~ 122°F)	-10°C ~ 50°C (14°F ~ 122°F)	-10°C ~ 50°C (14°F ~ 122°F)	-10°C ~ 50°C (14°F ~ 122°F)
UL listed temperature	0°C ~ 37.8°C (32°F ~ 100°F)	0°C ~ 37.8°C (32°F ~ 100°F)	0°C ~ 47°C (32°F ~ 115°F)	0°C ~ 47°C (32°F ~ 115°F)	0°C ~ 47°C (32°F ~ 115°F)
Storage Temperature	-20°C ~ 60°C (-4°F ~ 140°F)	-20°C ~ 60°C (-4°F ~ 140°F)	-20°C ~ 60°C (-4°F ~ 140°F)	-20°C ~ 60°C (-4°F ~ 140°F)	-20°C ~ 60°C (-4°F ~ 140°F)
Test	*	*	*	N/A	N/A
Dimensions	3-15/16"D X 1-1/2"H	3-15/16"D X 1-1/2"H	3-15/16"D X 1-9/16"H	5-7/8"D X 15/32"H	4-1/8"D X 5/16"H
Environment	Indoor Use Only	Indoor Use Only	Indoor Use Only	Indoor Use Only	Indoor Use Only
Visual Alarm/ Power Indicator	Dual LED	Dual LED	Dual LED	See Sensor	See Sensor
Address Setting	*	*	*	N/A	N/A

* = See Control Panel For proper address setting and testing procedure.

SENSITIVITY RANGES		
VELOCITY (fpm)	FWC-FSLC-SMKALG (%/ft.)	FWC-FSLC-SMK (%/ft.)
300	.88 ~ 3.57	0.5 ~ 3.80
2000	.88 ~ 2.81	0.5 ~ 2.74
4000	.88 ~ 2.52	0.5 ~ 2.68

BASE	BOX MOUNTING		
	3"-O	4"-O	4"-S
FWC-FSLC-SMK6B	YES	YES	YES
FWC-FSLC-SMK4B	YES	NO	NO

WARNING!!!!
 Failure to follow these instructions may result in the failure of the detector to initiate an alarm condition. Napco is not responsible for detectors that have been improperly installed, tested or maintained.

ATTENTION!!!!
 INSTALLATION WIRING SHALL NOT EXCEED 50 OHMS (14-18 AWG.) MAXIMUM OF 1 CONDUCTOR PER TERMINAL.

Firewolf™ is a Registered trademark of NAPCO.



Napco Security Systems, Inc.
 333 Bayview Avenue * Amityville, NY 11701
 Phone: (800) 645-9445 (631) 842-9400 Fax: (631) 789-3383

WI1709
 PG 1 OF 2

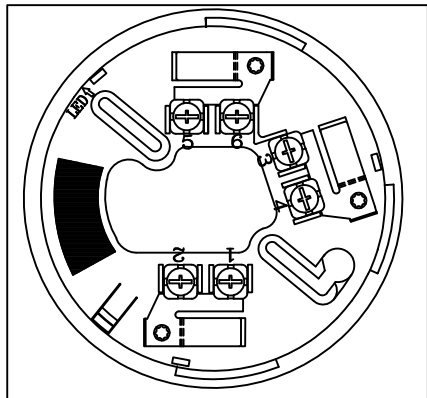

FWC-FSLC-SMK4B BASE

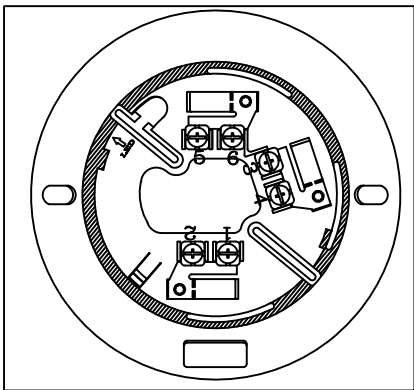
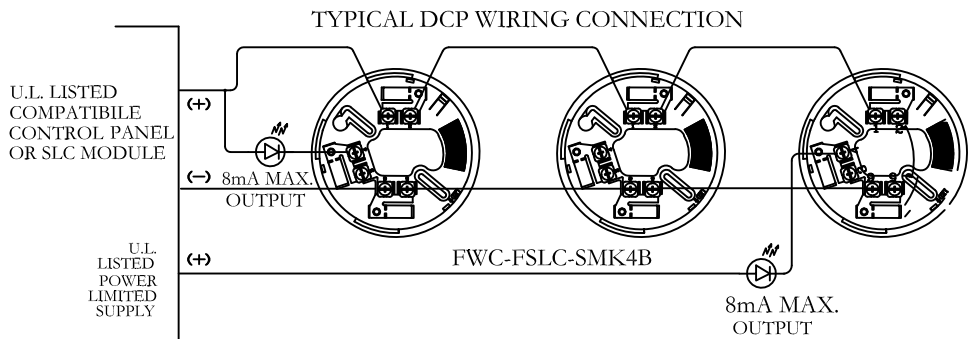

FWC-FSLC-SMK6B BASE

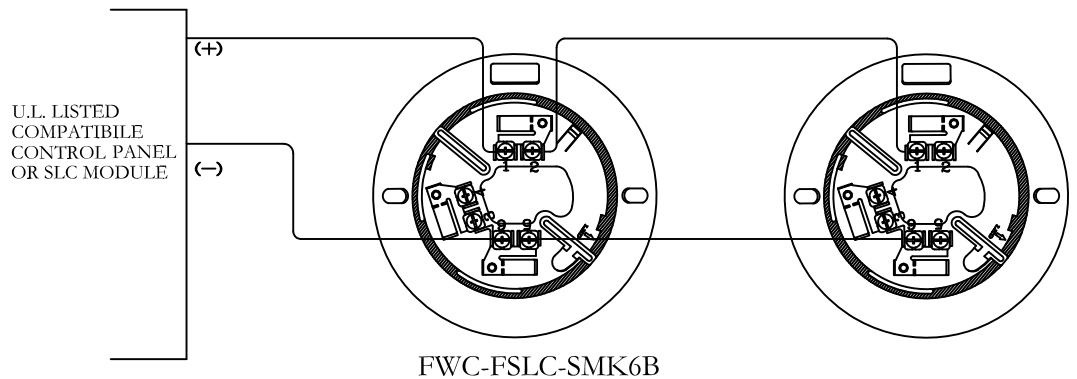

INSTRUCTION FOR IMPLEMENTING THE SECURITY FEATURE

The following instructions will enable the user to activate the security feature and to release the base security locking tab so as to remove the sensor from the base.

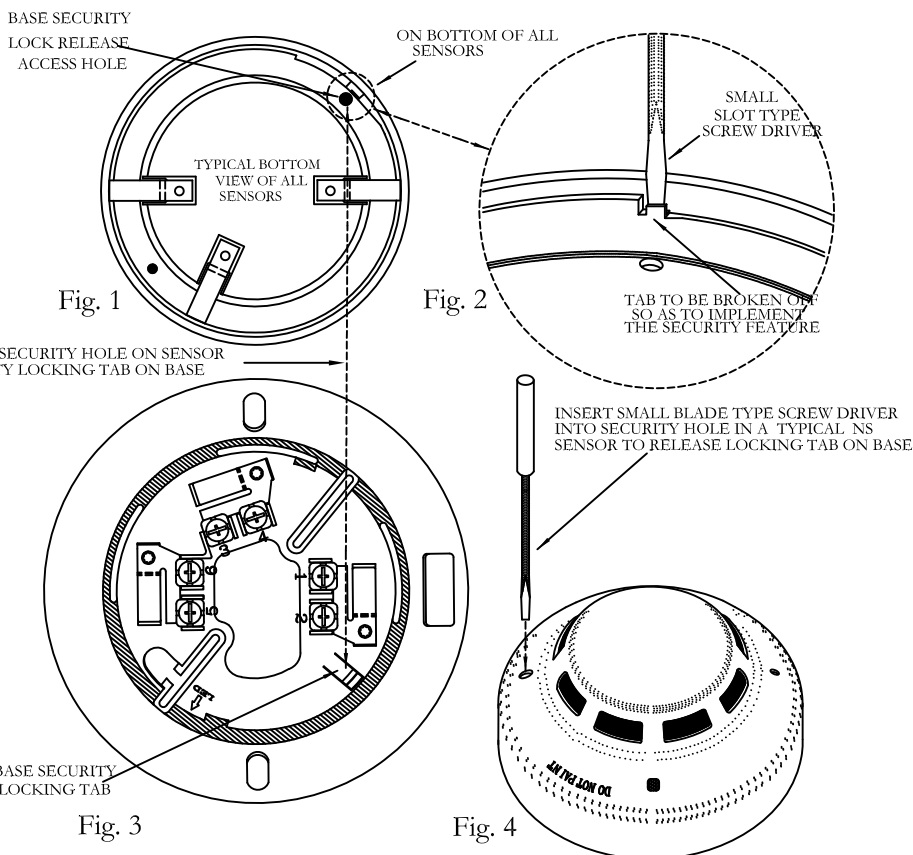

- 1) Take any sensor and turn it over to view the bottom as shown in Fig. 1. Using a small blade type screw driver break the tab as shown in Fig. 2. This will allow the base security locking tab, as shown in Fig. 3 to stay elevated. This will prevent the sensor from being removed from its base.
- 2) To remove the sensor from its base, take a small diameter screw driver and insert it into the large hole on the outer rim of the sensor (see Fig. 4). Use caution when pushing the base security locking tab down. Only use enough force to remove the sensor. While pushing the tab down rotate the sensor counter clockwise enough to clear the base security locking tab. Once this is accomplished the sensor can be completely removed.

CAUTION!!! DO NOT USE EXCESSIVE FORCE WHEN UNLOCKING THE BASE SECURITY LOCKING TAB